

VOLVO COMPACT EXCAVATORS

EC25, EC30

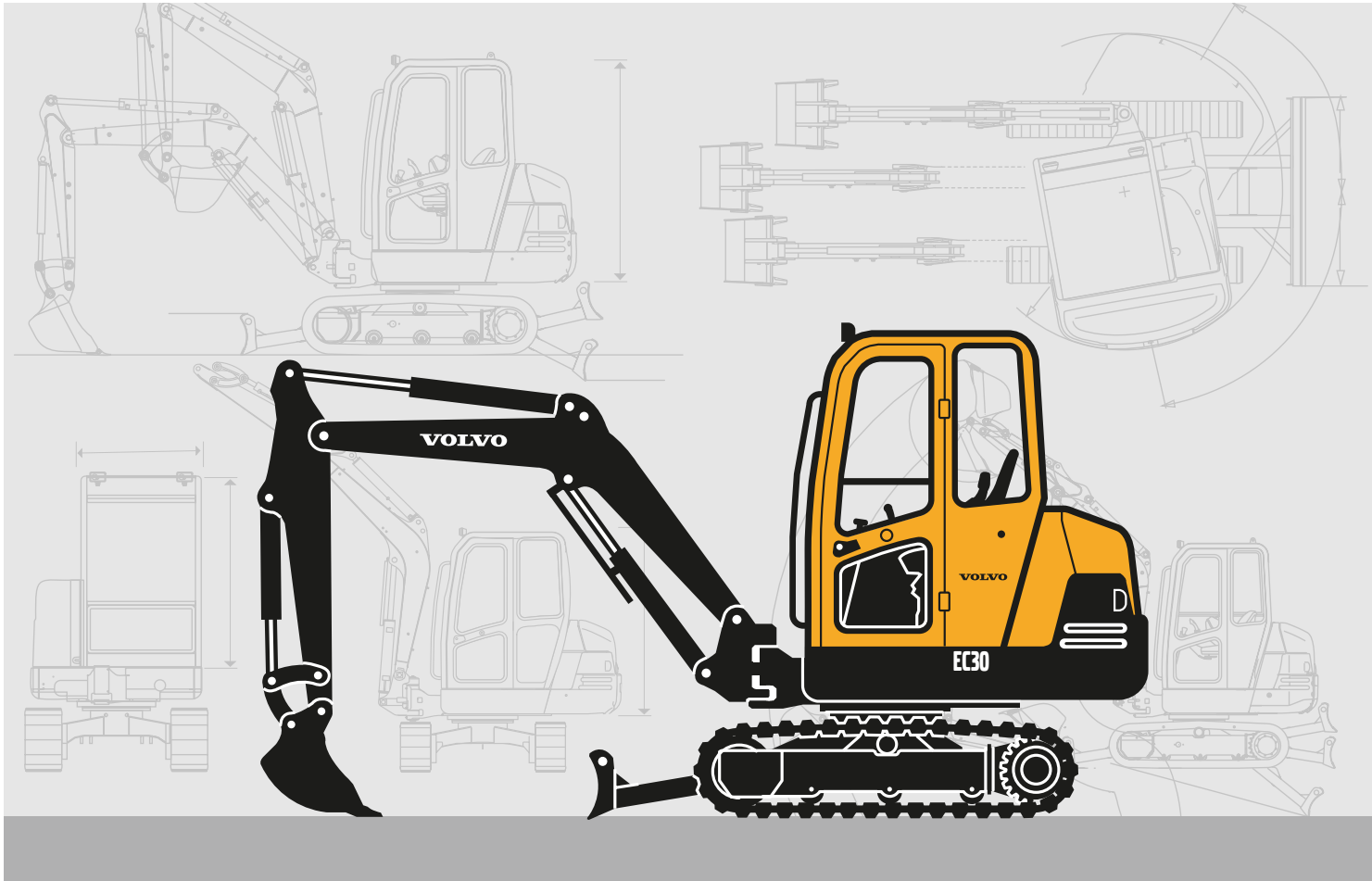

- **Gross Power:**

EC25 - ISO 9249: 20 kW / 27.2 hp
EC30 - ISO 9249: 20 kW / 27.2 hp

- **Net Power :**

EC25 - ISO 9249: 17.1 kW / 23 hp
EC30 - ISO 9249: 17.8 kW / 24.2 hp

- **Operating Weight:**

EC25 - 2664 - 2790 kg
EC30 - 2964 - 3151 kg

- **Bucket Capacities:**

35 - 153 l.

- **Maximum Digging Depth:**

EC25 - 2840 - 3140 mm
EC30 - 3030 - 3330 mm

- **Load Sensing Hydraulic System** for very precise controls under all load conditions.

- **Simultaneous digging movements and high speed** operations for faster cycle times and increased productivity.

- **ROPS, TOPS and FOPS** cab and canopy for a better operator safety.

- **Compact dimensions. Wrap-around counterweight** protects the rear compartment against all impacts.

- **Two travel speeds** for higher mobility on job sites.

- **Excellent serviceability** thanks to easy access to the engine and hydraulics compartments.

- **X-shaped lengthened undercarriage** for better rigidity and stability.

MORE CARE. BUILT IN.



SPECIFICATIONS - EC25, EC30

Engine

Water-cooled Mitsubishi 3-cylinder diesel engine.

Model	S3L2
Gross power, rated	20 kW (27.2 hp) at 2800 r/min
Power, installed (ISO 9249)	EC25 : 17.1 kW (23 hp) at 2200 r/min EC30 : 17.8 kW (24.2 hp) at 2400 r/min
Displacement, total	1318 cc
Maximum torque (ISO 9249)	77 Nm at 1600 r/min
Bore x stroke	78 mm x 92 mm

Electrical system

Rated voltage	12 V
Battery capacity	12 V - 70 Ah
Alternator rating	12 V - 50 A
Starter motor output	12 V - 2 kW

Hydraulic system

Closed centre Load Sensing hydraulic system providing total independence of each movement.

Control	power-assisted hydraulic controls
----------------	-----------------------------------

Variable displacement Load Sensing pump for all the equipment and travel circuits:

Maximum flow	62 l/min
Maximum operating pressure	EC25 : 23 MPa (230 bars) EC30 : 25 MPa (250 bars)

Gear pump for the power assistance circuit:

Maximum flow	17.6 l/min
Maximum operating pressure	32 MPa (32 bars)

Double-acting hydraulic circuit for accessories:

Maximum flow	45 l/min
Maximum operating pressure	EC25 : 23 MPa (230 bars) EC30 : 25 MPa (250 bars)

End-of-stroke cushions

On boom ram	at the end of the rod extension
--------------------	---------------------------------

Bucket performance

Breakout force	EC25 : 2180 daN	EC30 : 2420 daN
Tearout force	EC25 : 1490 daN	EC30 : 1720 daN

Slewing system

Turntable slewing is provided by a radial piston hydraulic motor which drives directly (without a reduction gear) a ball internal crown wheel with remote lubrication:

Slewing speed	10 r/min
Turntable braking	automatic multi-disc brake
Absorption of hydraulic shocks	Hydrosensor shockless valve

Undercarriage

The undercarriage is made up of an "X" box fabricated centre part for more rigidity and of sloping side members for a better clearance of materials. The rollers and the tensioning wheels are lubricated for life.

Bottom/top rollers per side	3/1
Track width	300 mm
Track tension	by grease piston
Blade (width x height)	1530 x 340 mm

Drivetrain

Each track is driven by an axial piston hydraulic motor equipped with two speeds and an epicyclic reduction gear.

Max. speed (low/high speed)	2,4~3,7 km/h / 1,5~2,3 mph	
Max. tractive force	EC25 : 2530 daN	EC30 : 2750 daN

The forward movement control is automatically locked when the operator raises the left console.

Service fill capacities

Fuel tank	49 l
Hydraulic tank	19,5 l
Hydraulic system, total	46,5 l
Engine oil	5,2 l
Cooling system	6 l

Weight

EC25

Ground pressure	Rubber Tracks	Steel Tracks
Cab version	0.30 kg/cm ²	0,31 kg/cm ²
Canopy version	0.29 kg/cm ²	0.30 kg/cm ²

Operating mass	Rubber Tracks	Steel Tracks
Cab version	2790 kg	2851 kg
Canopy version	2664 kg	2725 kg

Transport mass	Rubber Tracks	Steel Tracks
Cab version	2649 kg	2710 kg
Canopy version	2523 kg	2584 kg

EC30

Ground pressure	Rubber Tracks	Steel Tracks
Cab version	0.32 kg/cm ²	0,33 kg/cm ²
Canopy version	0.31 kg/cm ²	0.32 kg/cm ²

Operating mass	Rubber Tracks	Steel Tracks
Cab version	3090 kg	3151 kg
Canopy version	2964 kg	3025 kg



Noise levels

The EC25 conforms to the 2006 European Machine Directive Noise Level (2000/14/CE) of 94 dB(A) for this class of machine.

The EC30 conforms to the 2006 European Machine Directive Noise Level (2000/14/CE) of 94 dB(A) for this class of machine.

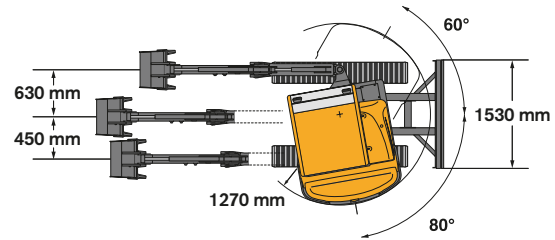
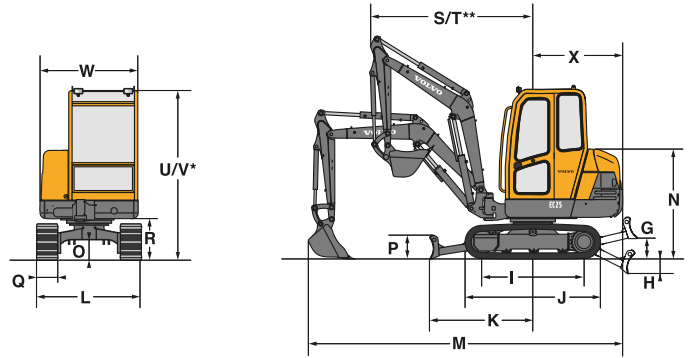
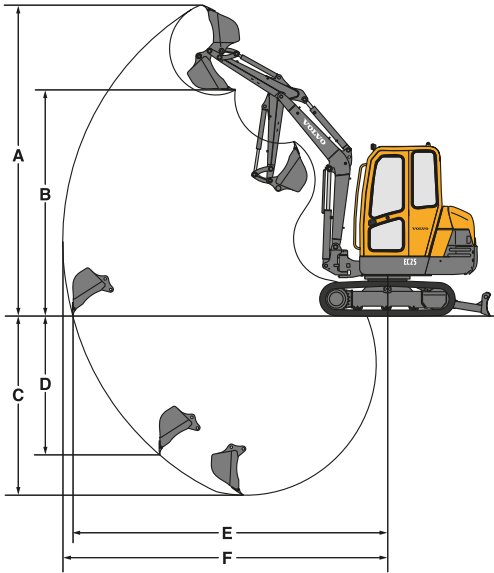
SPECIFICATIONS - EC25



Backhoe buckets			
	Width	Weight	Capacity
Excavator bucket	250 mm	40 kg	35 l
	300 mm	46 kg	37 l
	400 mm	55 kg	55 l
	450 mm	60 kg	65 l
	500 mm	66 kg	73 l
	600 mm	75 kg	91 l
	750 mm	84 kg	119 l
Ditch bucket	1300 mm	125 kg	153

Dipper	A	B	C*	C	D	E	F
1200 mm	4330	3130	2840	2520	2000	4460	4580
1500 mm	4520	3320	3140	2820	2290	4750	4870



* Dig depth with blade down.

G	H	I	J	K	L	M	N	O
390	520	1440	1910	1450	1480	4220	1550	280

P	Q	R	S	T	U	V	W	X
340	300	570	1830	1420	2390	2350	1420	1260

These capacities are given for a machine without a bucket or quick-release coupling and fitted with rubber tracks for a 360° total rotation lifted load. The handling capacity is 75% of the tipping load or 87% of the hydraulic limit.

Caution: In accordance with standard EN 474-5, the machine must be equipped with a safety valve on the boom ram and an overload indicator (available as options) to carry out handling operations.

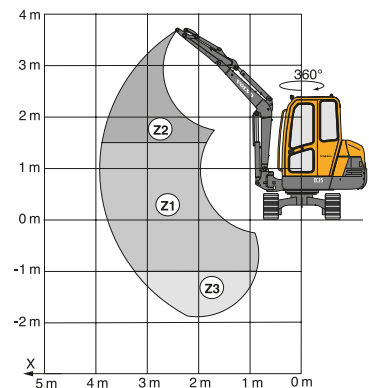

Outreach		1,50 m	2,00 m	2,50 m	3,00 m	3,50 m	3,90 m	4,00 m
	1200 mm 	Z2	975	710*	540	430		
		Z1	1470	905	655	515	420	360
		Z3	1490	925	665	520		
	1500 mm 	Z2	885*	710*	470*	430		350
		Z1	1015*	900	650	505	410	345
		Z3	1465	910	655	510	415	

* hydraulic limit

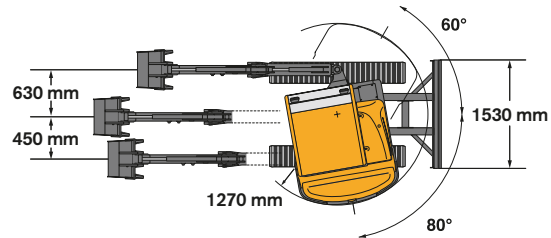
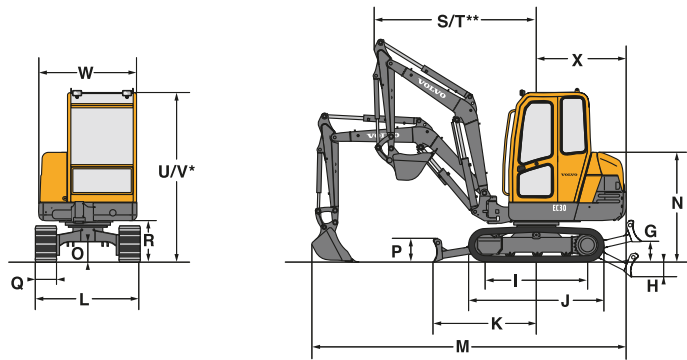
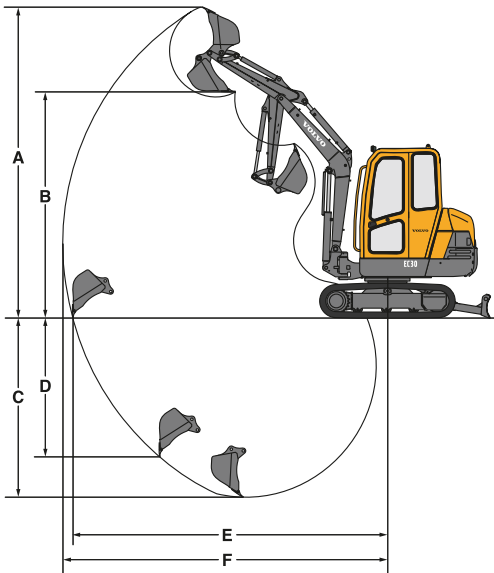

SPECIFICATIONS - EC30



Backhoe buckets			
	Width	Weight	Capacity
Excavator bucket	250 mm	41 kg	35 l
	300 mm	47 kg	37 l
	400 mm	57 kg	55 l
	450 mm	63 kg	65 l
	500 mm	68 kg	73 l
	600 mm	78 kg	91 l
	750 mm	88 kg	119 l
Ditch bucket	1300 mm	125 kg	153 l

Dipper	A	B	C*	C	D	E	F
1200 mm	4450	3250	3030	2740	2150	4620	4740
1500 mm	4640	3430	3330	3040	2440	4910	5030

* Dig depth with blade down.

G	H	I	J	K	L	M	N	O
390	520	1440	1910	1450	1480	4370	1550	280

P	Q	R	S	T	U	V	W	X
340	300	570	1950	1530	2390	2340	1420	1260

These capacities are given for a machine without a bucket or quick-release coupling and fitted with rubber tracks for a 360° total rotation lifted load. The handling capacity is 75% of the tipping load or 87% of the hydraulic limit.

Caution: In accordance with standard EN 474-5, the machine must be equipped with a safety valve on the boom ram and an overload indicator (available as options) to carry out handling operations.

Outreach		1,50 m	2,00 m	2,50 m	3,00 m	3,50 m	3,90 m	4,00 m	
	1200 mm	Z2	1030	745	575	460	380		
		Z1	1520*	970	705	550	450	380	
		Z3	1595	990	710	555			
	1500 mm	Z2	1055	755	580	465	380		
		Z1	880*	965	695	540	440	370	335
		Z3	1570	975	700	545	445		

* hydraulic limit

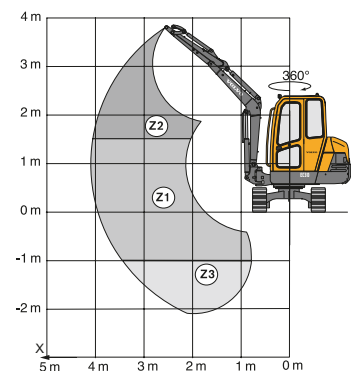

STANDARD EQUIPMENT

Engine

Dry-type air filter.
Electric pre-heating device.
Transparent diesel oil filter, pre-filter and sediment chamber.
Purge plug under the diesel oil tank.
Oil sump sheet metal guard.
Continuous adjustment of engine speed.

Electrical system

12 V - 70 Ah battery.
Horn.
12 V power socket for inspection lamp.

Undercarriage

300 mm wide rubber tracks.
Dozer blade.
Towing and anchoring rings.
Remote lubrication of the slewing crown ring.

Hydraulic system

ISO power-assisted hydraulic controls.
Additional double-acting hydraulic control valve for an attachment circuit with folding control pedal and circuit for direct return of oil to the hydraulic tank.
Attachment circuit piping (double-acting + return) as far as the bottom of the boom.
Power-assisted control of the hydraulic offset of the boom by the left control lever.
Control of forward movement by two levers coupled to pedals.

Cab (cab version)

Level 1 FOPS (Falling Objects Protective Structure).
TOPS (Tip-Over Protective Structure).
ROPS (Roll-Over Protective Structure).
Fabric-covered multi-adjustable sprung seat.
Non-slip floor and grab handle access to the driver's cab.

Seatbelt.
Cab mounted on rubber mountings.
Two working lights.
Two-speed heating and ventilation.
Cab heating adjustment.
Front window with opening system power-assisted by two gas rams.
Sliding window (right).
Door stops.
Provision for a radio (location for a radio and two speakers, aerial and electric wiring already fitted).
Interior lighting.
Anti-corrosion protection of the cab by electrophoresis.
Windscreen wiper and washer (front).
Emergency exit via the rear window.

Canopy (Canopy version)

Level 1 FOPS (Falling Objects Protective Structure).
TOPS (Tip-Over Protective Structure).
ROPS (Roll-Over Protective Structure).
Vinyl-covered multi-adjustable sprung seat.
Non-slip floor and grab handle for access to the driver's cab.
Seat belt.
Working light on the canopy frame.

Instrumentation and monitoring

Monitoring and warning light for:
pre-heating, engine oil pressure, water temperature, battery charging, hydraulic filter restriction, air filter restriction.
Fuel gauge.
Hour meter.
Device for automatic switching off of engine in the event of overheating or drop in oil pressure.

Working equipment

EC25 - 2100 mm long monobloc boom.
EC30 - 2300 mm long monobloc boom.
1200 mm dipper.
140° hydraulic boom offset.
Cushion on the boom ram.
Handling equipment for a load less than 1000 kg (hooking device on the bucket rod and load table displayed in the driver's cab).
Remote lubrication of the bottom of the offset ram.

Safety

Device for locking the earthwork equipment's controls and the travel levers when the left console is raised to gain access to the driver's cab.
Engine starting safety device : the left console must be raised to operate the starter.
Pressure accumulator on the power assistance circuit in order to be able to put the equipment on the ground if the engine is switched off.
Window-breaker hammer (cab).
Key-lockable toolbox.

Official approval

Machine conforming to directive n° 98/37 EEC and its amendments.
Sources emissions in the environment conforming to directive 2000/14/CE.
Handling device conforming to EN standard 474-5.
FOPS 1 conforming to ISO standard 3449.
TOPS conforming to ISO standard 12117.
Electromagnetic compatibility (EMC) conforming to directive n° 89/336 EEC and its amendments.

OPTIONAL EQUIPEMENT

Working equipment

Long dipper (1500 mm).
Safety valve piloted by the power assistance circuit on the boom ram with overload indicator (for handling loads over 1000 kg).
Safety valve on the dipper ram.
Mechanically-controlled quickchange attachment coupling.
Hydraulically-controlled quickchange attachment coupling.

Hydraulic circuits for attachments

Circuit for hydraulic breaker with direct return to the tank.
Hydraulic circuit for doubleacting attachments.
Hydraulic circuit for operating a clam-shell bucket (opening/closing and rotation of the bucket).

Undercarriage

Steel tracks (300 mm wide).

Lighting

Additional working light on the boom.
Additional rear working light.
Revolving light.

Environmental protection

Bio-degradable hydraulic oil.
Catalytic exhaust.

Comfort and safety

Radio (cab).
Anti-theft system (2 programmable codes).
Electric circuit-breaker.
Rear wind-cutter protection on canopy.

Service and maintenance

Tool kit.
Miscellaneous.
Special customised paint (RAL specifications).



Volvo Construction Equipment is different. It's designed, built and supported in a different way. That difference comes from an engineering heritage of over 170 years. A heritage of thinking first about the people who actually use the machines. About how to help them be safer, more comfortable, more productive. About the environment we all share. The result of that thinking is a growing range of machines and a global support network dedicated to helping you do more. People around the world are proud to use Volvo. And we're proud of what makes Volvo different – **More care. Built in.**



All products are not available in all markets. Under our policy of continuous improvement, we reserve the right to change specifications and design without prior notice. The illustrations do not necessarily show the standard version of the machine.

VOLVO

Construction Equipment

www.volvoce.com

Ref No. 21 2 432 1165
Printed in PDF
Volvo, Belley

English
2006.12
CEX